

GAS PRESSURE REGULATORS CATALOG

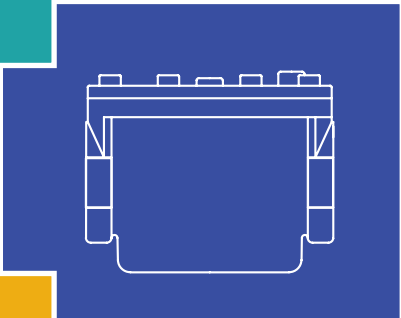
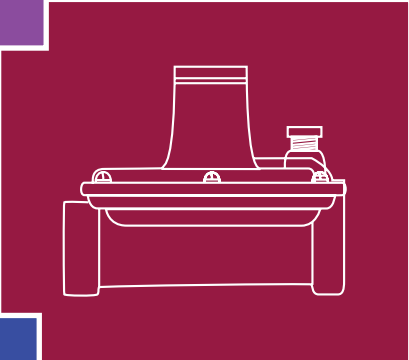
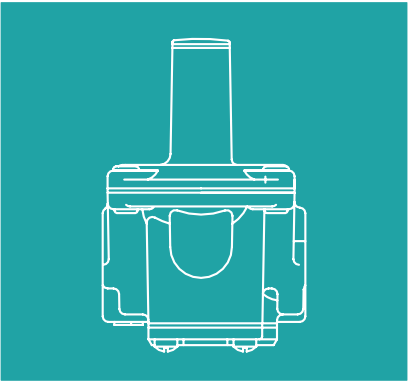
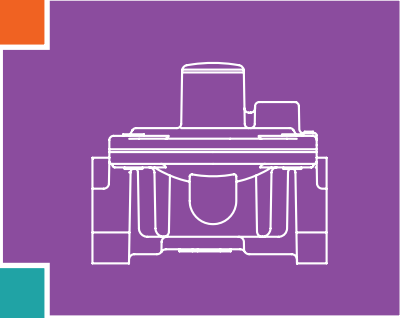
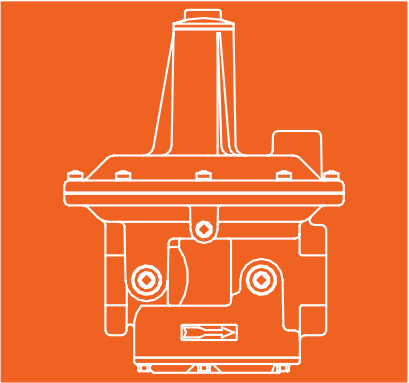

⚠ WARNING

Service and installation must be performed by a trained/experienced service technician.

All products used with combustible gas **must** be installed and used **strictly** in accordance with the instructions of the Original Equipment Manufacturer (OEM) and with all applicable government codes and regulations, e.g. plumbing, mechanical, and electrical codes and practices. Maxitrol products should be installed and operated in accordance with Maxitrol Safety Warning Instructions.

Maxitrol Company is NOT responsible for any errors or omissions in reliance by anyone of any information set forth in this catalog without additional reference to local requirements and applicable ordinances or codes.

Other worldwide approvals and certifications available upon inquiry.



RV SERIES

Rubber Seat Poppet Design

The compact RV poppet regulators are designed primarily for main burner and pilot load applications. Typical applications include residential and commercial cooking appliances, barbecues, hearth products, and pilot lines. Maxitrol rubber seat poppet models offer the ultimate in design features and performance capabilities to meet your specific appliance or utility requirements.

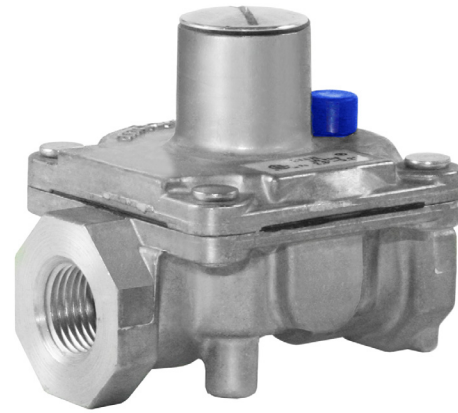

RV47

Specifications

- Pipe Sizes** 1/8" thru 3/4" threaded connections with NPT or ISO7-1 threads.
(Other connections available, please consult Maxitrol Company.)
- Housing Material** RV12, RV20, RV47, RV48, CV47: aluminum.
- Mounting** All models, with the exception of "D" suffix models, are suitable for multi-positional mounting. Other than upright position will result in a slight difference in outlet pressure. "D" suffix models are to be mounted upright only.
NOTE: All Maxitrol gas pressure regulators should be installed and operated in accordance with Maxitrol Safety Warning Instructions (see GPR_MI_EN.ES or GPR_CSA_MI_EN.FR).
- Certifications** RV Series: ANSI Z21.18/CSA 6.3 Gas Appliance Pressure Regulators.
CV47 Series: ANSI Z21.78/CSA 6.20 Combination Gas Controls for Gas Appliances.
- Gas Types (RV Series)** Suitable for natural, manufactured, mixed gases, liquefied petroleum gases, and LP gas-air mixtures.
- Gas Types (CV47 Series)** Suitable for natural or liquefied petroleum gases.
- Maximum Inlet Pressure** 1/2 psi (3.4 kPa)
- Emergency Exposure Limits** 2.5 psi (17.2 kPa)
- Ambient Temperature Ranges**... RV20, RV47, RV48, CV47: 32° to 225°F (0° to 107°C)
RV12: -40° to 225°F (-40° to 107°C)
RV12T: -40° to 275°F (-40° to 135°C)
RV20T: -40° to 300°F (-40° to 148°C)
RV48T: 32° to 275°F (0° to 135°C)
- Minimum Regulation**..... Suitable for pilot flow applications. (P) (Circle P) (0.15 CFH NG), (P) (Delta P) (0.50 CFH NG), None (1.5 CFH NG), N Models (3 CFH NG).



Model Designations

Models having a suffix letter or a combination of suffix letters listed below indicates the design modifications described.

- A** Limited spring adjustment (RV47A & CV47A**, short stack*).
- C** Convertible regulators***; preset to deliver outlet pressures for either natural or LP gases.
(RV20, RV47, RV48, CV47)
- D** Integral ball check limiting device; permits higher maximum individual load.
(see Capacities and Pressure Drop, page 6)
- E** Excessive pressure rated.
- F** Factory-set; fixed/non-adjustable regulator.
- I** Left side integral manual valve; outlet faces main inlet (CV47).
- L** Integral vent limiting orifice as the breather hole.
- M** B.S.P. - PL parallel thread - conforms to ISO 7-1, where pressure tight joints are made on the threads.
- MK** B.S.P. - TR taper thread - conforms to ISO 7-1, where pressure tight joints are made on the threads.
- N** Internal by-pass orifice to prevent lockup. Main burner only (RV20, RV47, RV48, CV47).
- R** Right side+ integral manual valve; outlet faces main outlet (CV47).
- SR** Side pressure tap; right side+ 1/8" NPT (RV20 & RV47).
- S** Side pressure tap; left side+ 1/8" NPT (RV20, RV47, CV47).
- T** Higher ambient temperature range.
- V** Threaded vent connector, 5/16-24 for 1/8" tubing connection (RV20).

* Short stack models have an adjustment range of less than 2" w.c. (0.5 kPa); these models are advantageous where installation must be made in a limited space.

** CV47A is best described as a RV47A with an extra regulated outlet. This outlet contains an integral manual valve located on the valve body's side.

*** Convertible regulators are designed to deliver either of two fixed outlet pressures for natural or LP gases.

RV20C: NAT GAS: 4.0" w.c. (1.0 kPa); LP: 10" w.c. (2.5 kPa)

RV47C, CV47C: NAT GAS: 4.0", 5.0" or 6.0" w.c. (1.0, 1.3, or 1.5 kPa); LP: 10" or 11" w.c. (2.5 or 2.8 kPa)

RV48C: NAT GAS: 5" w.c. (1.3 kPa); LP: 10" w.c. (2.5 kPa)

+ Left and right is determined when viewing regulator from outlet side with stack up.

NOTE: The RV48 model may be used with either a 12A04 ball check device, or a 12A06 fixed orifice vent limiting device. See page 62 for vent accessory options.

RV SERIES

Rubber Seat Poppet Design

Capacities and Pressure Drop

Capacities expressed in Btu/h (m³/h) @ 0.64 sp gr gas

Model	Pipe Size	Pressure Drop @ 0.3" w.c. or (0.07 kPa)	Range of Regulation		Individual Load	
			Main Burner	Main Burner & Pilot	Fixed Orifice	Ball Check Device
RV12	1/8" x 1/8"*	14,800 (0.42)	30,000 (0.85)	25,000 (0.71)	20,000 (0.56)	---
	3/16" x 3/16" Loxit	8,800 (0.25)		15,000 (0.43)		
RV20	1/4" x 1/4" 3/8" x 3/8"*	30,000 (0.85)	65,000 (1.84)	50,000 (1.4)	30,000 (0.85)	---
RV20C	1/4" x 1/4" 3/8" x 3/8"	30,000 (0.85)	75,000 (2.11)	50,000 (1.4)	15,000 (0.42)	---
CV47 RV47	3/8" x 3/8"	55,000 (1.5)	125,000 (3.5)	90,000 (2.5)	40,000 (1.1)	125,000 (3.5)
	1/2" x 1/2"*	60,000 (1.7)				
CV47A or C RV47A or C	3/8" x 3/8"	55,000 (1.5)	125,000 (3.5)	125,000 (3.5)	40,000 (1.1)	125,000 (3.5)
	1/2" x 1/2"	60,000 (1.7)				
RV48	1/2" x 1/2"	130,000 (3.7)	230,000 (6.5)	230,000 (6.5)	40,000 (1.1)	160,000 (4.5)
	3/4" x 3/4"	150,000 (4.2)	250,000 (7.1)	250,000 (7.1)		
RV48C	1/2" x 1/2"	130,000 (3.7)	400,000 (11.3)	275,000 Nat (7.8) 275,000 LP (3.1)	40,000 (1.1)	160,000 (4.5)
	3/4" x 3/4"	150,000 (4.2)				

*Also available as Loxit connection.

NOTE: CSA maximum capacities vary with spring range and pipe size. Please contact Maxitrol directly for CSA maximums. Minimum main burner regulation capacity for all models (except "N") is 150 Btu/hr (0.0042 m³/h). See pages 58-59 for Regulator Sizing Requirements and Examples.

Spring Selection Chart: inches w.c. (kPa)

Model	Available Springs										
RV12	1 to 3.5* (0.25 to 0.9) Brown	2.8 to 5.2 (0.69 to 1.3) Plated	---	4 to 8 (1 to 2) Orange	---	---	---	---	6 to 10 (1.5 to 2.5) Red	8 to 12 (2 to 3) Blue	---
RV20	1 to 3.5* (0.25 to 0.9) Brown	2.8 to 5.2 (0.69 to 1.3) Plated	---	4 to 8 (1 to 2) Orange	---	---	---	---	6 to 10 (1.5 to 2.5) Red	8 to 12 (2 to 3) Blue	9 to 12* (2.25 to 3) Plated
RV47 CV47	1 to 3.5* (0.25 to 0.9) Brown	2.8 to 5.2 (0.69 to 1.3) Plated	3.8 to 4.3 (0.95 to 1.08) Black	4 to 8 (1 to 2) Orange	4 to 12 (1 to 3) Violet	4.7 to 5.3 (1.18 to 1.33) Green	---	5.6 to 6.4 (1.4 to 1.6) Red	6 to 10 (1.5 to 2.5) Red	8 to 12 (2 to 3) Blue	9.7 to 11.3 (2.42 to 2.83) Plated
RV48	1 to 3.5* (0.25 to 0.9) Brown	3.0 to 6.0 (0.75 to 1.5) Plated	---	4 to 8 (1 to 2) Orange	---	---	5 to 12 (1.25 to 3) Blue	---	6 to 10 (1.5 to 2.5) Red	8 to 12* (2 to 3) Blue	---

*Uncertified Spring

NOTE: See pages 56-57 for complete Spring Selection Chart.

RV SERIES

Rubber Seat Poppet Design

Dimensions

Model	Pipe Size	Vent	Swing Radius	Dimensions			
				A	B	C	D
RV12	1/8" 3/16"Loxit	Integral	1.4" (35 mm)	1.7" (43 mm)	0.4" (10 mm)	1.7" (43 mm)	1.4" (35 mm)
RV20	1/4", 3/8"	Integral or 5/16-24	1.6" (41 mm)	2.1" (54 mm)	0.5" (13 mm)	2.4" (61 mm)	1.8" (45 mm)
RV47 CV47	3/8", 1/2"	Integral "D" or "L" suffix	1.9" (48 mm)	2.5" (64 mm)	0.6" (16 mm)	2.9" (75 mm)	2.3" (57 mm)
RV47A CV47A			1.6" (41 mm)	2.3" (57 mm)			
RV48	1/2", 3/4"	Integral or 1/8" NPT, 12A04 or 12A06 vent limiting device	2" (51 mm)	2.8" (70 mm)	0.8" (19 mm)	3.4" (86 mm)	3" (76 mm)

NOTE: Dimensions are maximums and to be used only as an aid in designing clearance for the valve.
Actual production dimensions may vary somewhat from those shown.

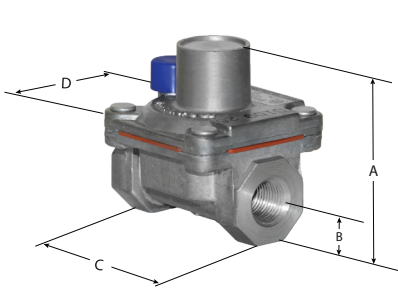

RV12

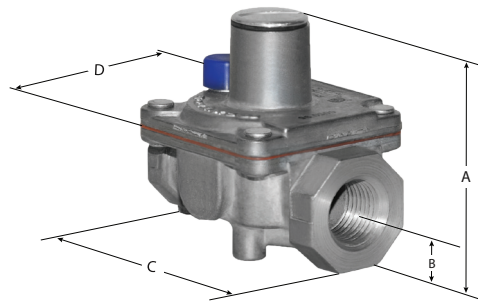

RV20

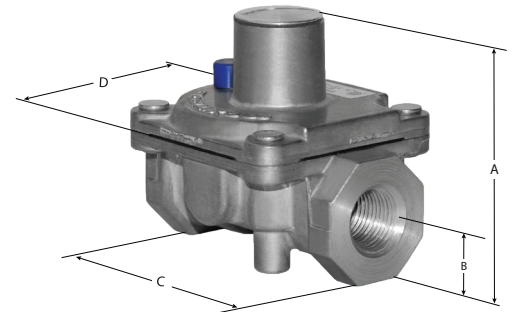

RV47, RV47A

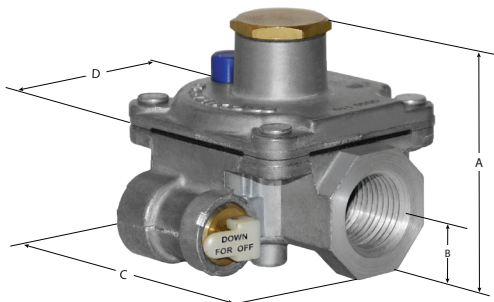

CV47, CV47A

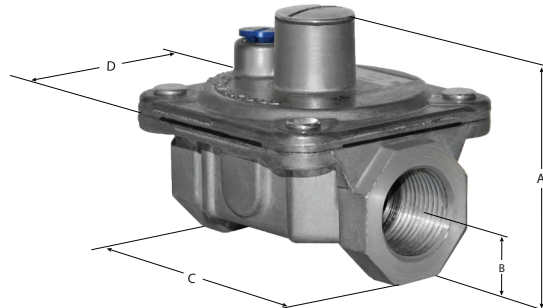

RV48

Rubber Seat Poppet Design

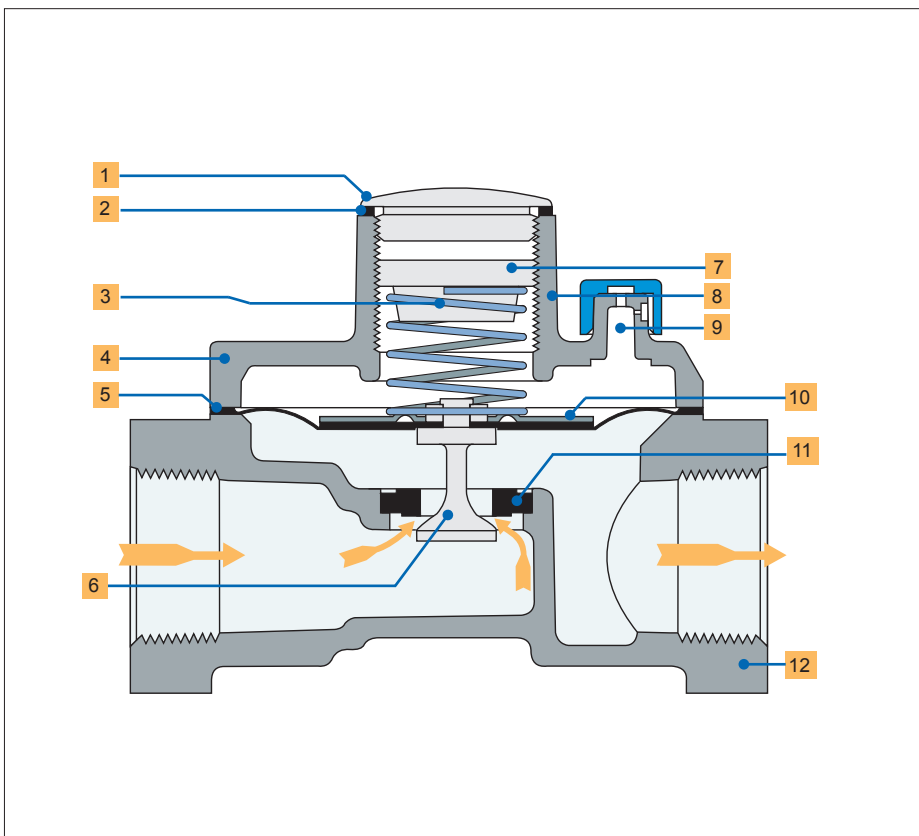

- 1** Seal Cap
- 2** Seal Cap Gasket
- 3** Spring
- 4** Top Housing
- 5** Diaphragm
- 6** Stem & Valve
- 7** Adjusting Screw
- 8** Stack
- 9** Vent
- 10** Diaphragm Plate
- 11** Rubber Seat
- 12** Bottom Housing

NOTE: Diagrams are graphical representations only and may differ from actual product.

